

# Finding the center of gravity



Physics

Mechanics

Forces, work, power &amp; energy



Difficulty level

easy



Group size

2



Preparation time

10 minutes



Execution time

10 minutes



## Teacher information

### Application



Lot method for determining the centre of gravity

The students should learn how to determine the center of gravity of regular and irregularly shaped bodies.

1. For this purpose they should balance the bodies on the one hand (e.g. on the tip of a pencil).
2. On the other hand, they should confirm their results by the soldering process.

The determination of the centre of gravity is essential for all major technical constructions (from cars to ships to high-rise buildings).

## Other teacher information

**PHYWE**  
excellence in science

### Prior knowledge



Since this experiment is about balancing even bodies, among other things, the students should already have completed the experiment "Force and Counterforce" in order to have a basic understanding of the balance of forces. In addition, a basic knowledge of the topic of density is recommended.

### Scientific



The centre of gravity (or centre of mass) of a body is the mean of the positions of its mass points, weighted by the mass. In the case of a homogeneous body (i.e. the same density everywhere), the centre of mass coincides with the geometric centre of gravity. In physics, the concept of the centre of gravity is used to reduce a complex, extended rigid body to a single mass point, for example to simplify the calculation of its trajectory when a force is applied.

## Other teacher information (2/2)

### Learning objective



The students should learn how to determine the centre of gravity of regularly and irregularly shaped bodies.

### Tasks



1. Students should determine the centre of gravity of regularly shaped bodies by balancing on a pencil tip.
2. On an irregularly shaped body, they shall determine the centre of gravity by at least two perpendiculars from different suspension points.
3. The results can be confirmed by the other procedure.

## Safety instructions

**PHYWE**  
excellence in science

The general instructions for safe experimentation in science lessons apply to this experiment.

**PHYWE**  
excellence in science

## Student Information

## Motivation

**PHYWE**  
excellence in science



Girl alone on seesaw

Everyone knows that you can't see-saw when you are sitting alone on a seesaw at its end. But if you stand in the middle of the support point, you can balance the seesaw. The reason for this is the shift of the centre of gravity of the seesaw relative to the supporting point, because you put an additional mass on the seesaw with your body.

Furthermore, the focus is very important in many technical application areas. These range from cars (elk test) to ships and high-rise buildings.

In this experiment you will learn two different methods to determine the centers of gravity of regular and irregular bodies.

## Tasks

**PHYWE**  
excellence in science



In this experiment you will learn how to experimentally determine the center of gravity of regular and irregular bodies using the following two methods:

1. Balancing the body on a point
2. The soldering process

## Equipment

Position	Material	Item No.	Quantity
1	Support base, variable	02001-00	1
2	Support rod, l = 600 mm, d = 10 mm, split in 2 rods with screw threads	02035-00	1
3	Boss head	02043-00	1
4	Holding pin	03949-00	1
5	Weight holder, 10 g	02204-00	1
6	Fishing line, l. 20m	02089-00	1

## Additional equipment

**PHYWE**  
excellence in science

Position	Equipment	Quantity
1	Template with different objects	1
2	Drawing cardboard (approx. DIN A4)	1
3	Glue	1
4	Scissors	1
5	Pencil	1

The template with the objects can be downloaded under the following link:

[Template with different objects](#)

## Set-up (1/3)

**PHYWE**  
excellence in science

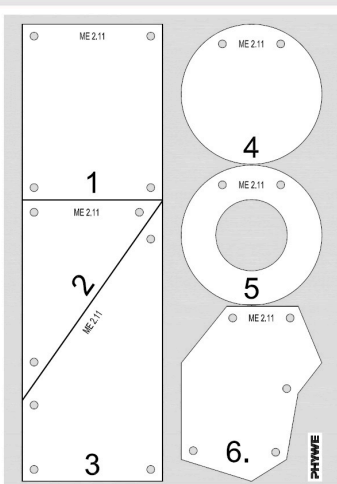

Templates

- Stick the printed template onto a cardboard box.
- Cut out the bodies (nos. 1-6).
- Drill small holes with the pencil at the indicated points in the cut-out bodies so that the retaining bolt fits through and can rotate freely. (Alternatively, a hole or similar can be used).

## Set-up (2/3)

**PHYWE**  
excellence in science

- Screw the two support rods together to form a long rod.
- Assemble the tripod base with the 60 cm long tripod rod.



Screw connection of the rods



Tripod foot



Tripod foot with tripod rod

## Set-up (3/3)

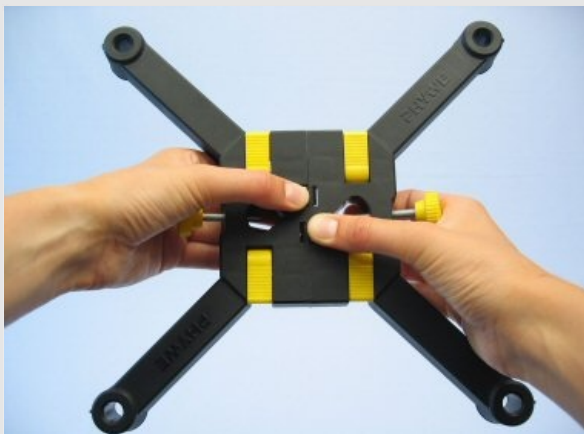
**PHYWE**  
excellence in science

Disassembling the tripod base

To disassemble the tripod base at the end, press the buttons in the middle and pull both halves apart.



## Procedure (1/3)

**PHYWE**  
excellence in science

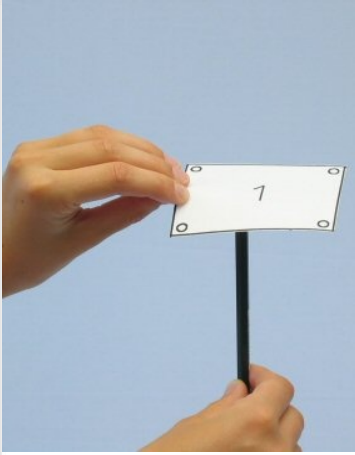

Balancing the regular body

- Balance the bodies 1 and 4 on a sharp pencil and try to find their centre of gravity as accurately as possible.
- Mark the found center of gravity with the pencil.

## Implementation (2/3)

**PHYWE**  
excellence in science



Lot procedure on the regular body

- Hang the two bodies with the different holes on the holding bolts.
- Fix the retaining bolt in the double socket.
- Hang the slotted weight plate with a piece of fishing line also on the holding bolt.
- Check if the string goes through your mark.

## Procedure (3/3)

**PHYWE**  
excellence in science

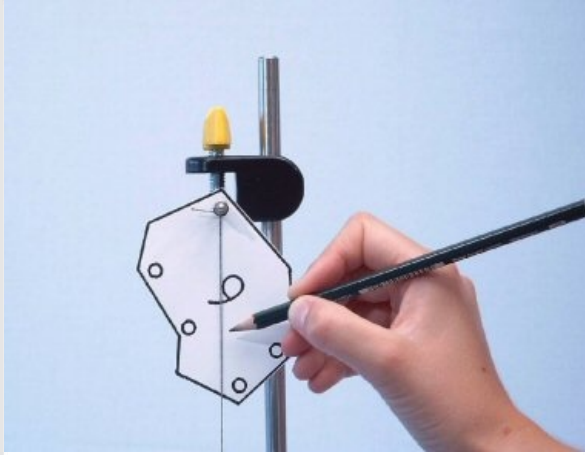

Soldering process on the irregular body

- Now use the irregularly shaped bodies one after the other.
- Hang it with one of the holes on the holding bolt.
- Mark the course of the string on it.
- Repeat this each time by hanging the body from other holes.
- Check whether these lines intersect in one point.
- Try to see if the bodies are in balance when you hold your pencil under the point of intersection.

**PHYWE**

## Report

## Task 1

**PHYWE**  
excellence in science

Do the marks of the centre of gravity of the regular bodies 1 and 4 coincide with the line given by the line?

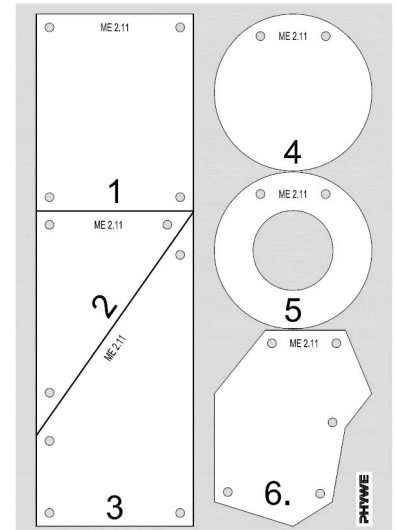
 No. Yes. Check

## Task 2

**PHYWE**  
excellence in science

What can be concluded from this?

 The center of gravity of regular bodies is always in the geometric center. There is no connection between the geometrical center and the center of gravity The center of gravity is not in the geometrical center of regular bodies. Check

### Task 3

Do you get the same emphasis in both procedures?

- No, not always.
- Yes, if it was done correctly and precisely.
- No, the proceedings do not have the same focus as the result.

✓ Check

### Task 4

Which method is generally more accurate?

- The plumb line method.
- The balancing.

✓ Check

## Task 5

Can you give a simple method for body 1, how to determine its center of gravity with pencil and ruler alone?

- It is not possible to determine the centre of gravity of body 1 with the aids.
- Divide the body into grids using the pen and ruler and try it out by balancing.
- Draw lines from corner to corner. The point of intersection represents the geometrical center and thus, due to the homogeneous distribution of mass, also the center of gravity.

[✓ Check](#)

Slide	Score/Total
Slide 18: Review of the identified priority area	0/1
Slide 19: Conclusion	0/1
Slide 20: Comparison of the procedures	0/1
Slide 21: Determination of the more precise methods	0/1
Slide 22: Determination of the centre of gravity of body 1	0/1

Total amount  0/5[👁 Solutions](#)[🔄 Repeat](#)